

LHT 51 M 200 G3-T3

Laser Diffuse Sensor with Background Suppression

- Automatic adjustment of transmit power
- Red light laser, with small laser spot
- 4-turn potentiometer
- Electrical background suppression
- Bright LED, Connector M8 with ring LED
- Light/dark switching

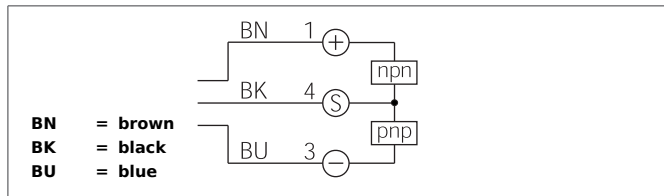

Safety instructions

Inproper use may result in hazardous radiation exposure. Pay attention to accident prevention rules and laser class. The instruments are not to be used for safety applications, in particular applications in which safety of persons depends on proper operation of the instruments. These instruments shall exclusively be used by qualified personnel.

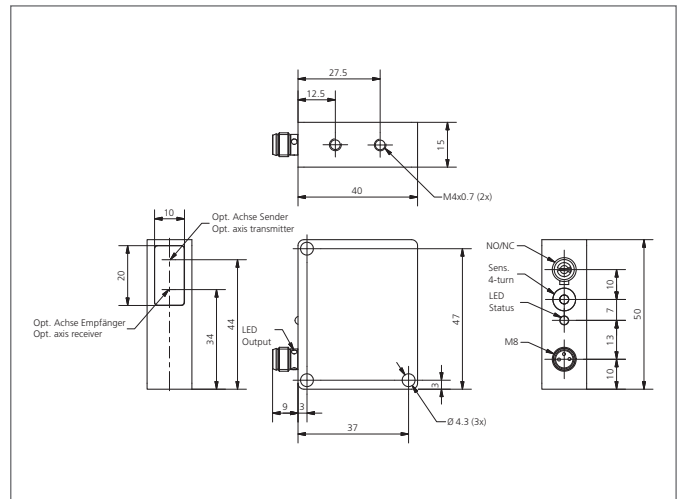

TECHNICAL INFORMATION (typ.)		+20°C, 24V DC
Operating principle		Diffuse reflective sensor
Evaluation		digital
Size		50 x 40 x 15 mm (Dimensions)
Design		cuboid design
Emitted light		Red light laser, 650 nm, clocked
Laser class		1 (IEC 60825-1)
Service voltage		10 ... 35 V DC
Internal power consumption		25 mA, (24 V DC)
background suppression		yes
Diameter of light spot		Ø 1,5 mm
Operating distance		50 ... 200 mm
Sensitivity adjustment		potentiometer
Switching output		Push pull, 200 mA, NO/NC, switchable
Switching hysteresis		6 % typ.
Display		LED: green - operation, yellow - output
Voltage drop		2,0 V
Switching frequency		500 Hz
Reproducibility		0,5%
Ambient temperature		-10 ... +50 °C
Ambient light immunity		5 kLx
Insulation voltage endurance		500 V
Protection class		IP 67
Protection degree		III, operation on protective low voltage

LHT 51 M 200 G3-T3

Laser Diffuse Sensor with Background Suppression

TECHNICAL INFORMATION (typ.)		+20°C, 24V DC
Casing material		Die-cast zinc black lacquered finish
Material		polycarbonate (Window)
Connection		Connector, M8, 3-poled
Connecting cable		TK ...